



US007441434B2

(12) **United States Patent**
Park et al.

(10) **Patent No.:** **US 7,441,434 B2**
(45) **Date of Patent:** **Oct. 28, 2008**

(54) **CHANNEL LETTER MACHINE AND METHOD THEREOF**

(75) Inventors: **Ju Woong Park**, Shiheung-si (KR);
Man Sik Cho, Shiheung-si (KR); **Sang Moo Lee**, Shiheung-si (KR);
Byoung-Young Song, Old Tappan, NJ (US)

(73) Assignee: **SDS USA, Inc.**, Northvale, NJ (US)

(*) Notice: Subject to any disclaimer, the term of this patent is extended or adjusted under 35 U.S.C. 154(b) by 124 days.

(21) Appl. No.: **11/431,246**

(22) Filed: **May 9, 2006**

(65) **Prior Publication Data**

US 2007/0261460 A1 Nov. 15, 2007

(51) **Int. Cl.**
B21D 43/28 (2006.01)

(52) **U.S. Cl.** **72/307; 72/294**

(58) **Field of Classification Search** **72/294, 72/307, 319, 379.2**

See application file for complete search history.

(56) **References Cited**

U.S. PATENT DOCUMENTS

3,097,684 A * 7/1963 Le Tarte 72/339

3,380,145 A *	4/1968	Stroud et al.	29/411
4,462,237 A *	7/1984	Kaufeler et al.	72/324
5,689,986 A *	11/1997	Jacobs, Jr.	72/7.4
5,771,725 A *	6/1998	Mizukawa	72/17.3
5,881,591 A	3/1999	Ondracek	
5,970,769 A *	10/1999	Lipari	72/131
6,158,264 A *	12/2000	Mizukawa	72/294
6,167,740 B1 *	1/2001	Lipari et al.	72/306

* cited by examiner

Primary Examiner—Daniel C Crane

(74) Attorney, Agent, or Firm—F. Chau & Associates, LLC

(57) **ABSTRACT**

A channel letter bending machine for bending a return of a channel letter from a stock includes a feeding unit disposed along a path of travel of the stock to be bent for feeding the stock, a flanging unit for forming a flange along one edge of the stock, a notching unit for notching the flange of the stock fed by the feeding mechanism along the path of travel, and a bending unit for bending the stock under the control of the computer control system into the desired configuration for the channel letter shape, wherein the notching unit and the flanging unit are disposed upstream of the bending unit and the flanging unit is disposed upstream of the notching unit.

20 Claims, 12 Drawing Sheets

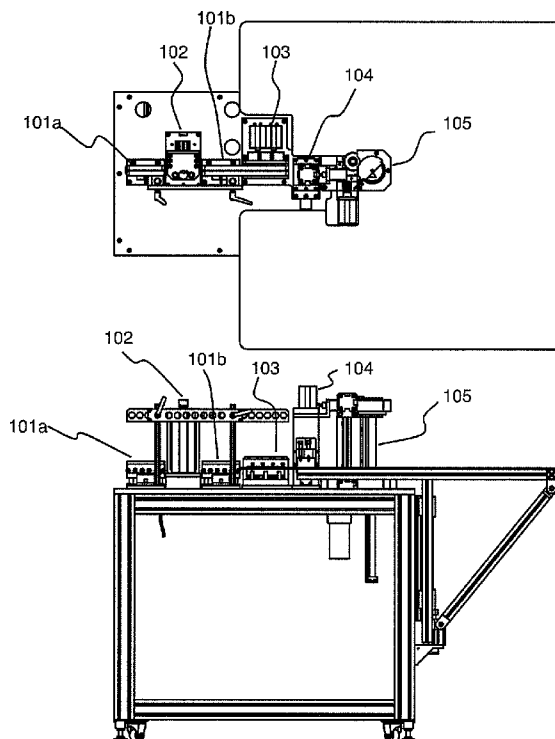

FIGURE 1A

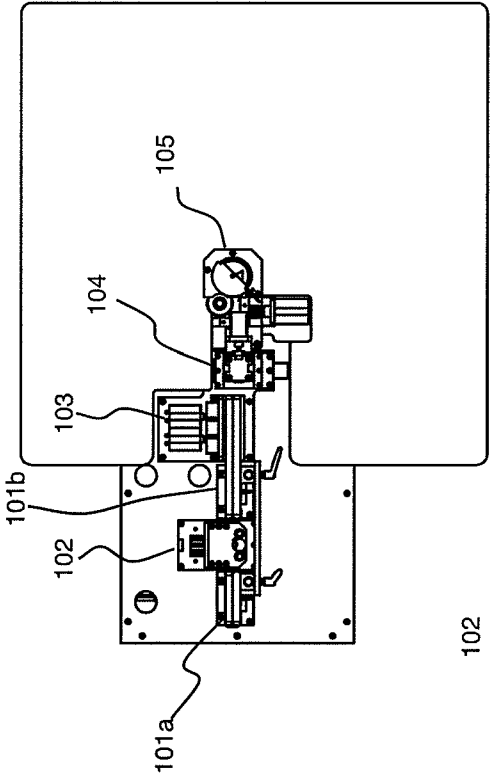

FIGURE 1B

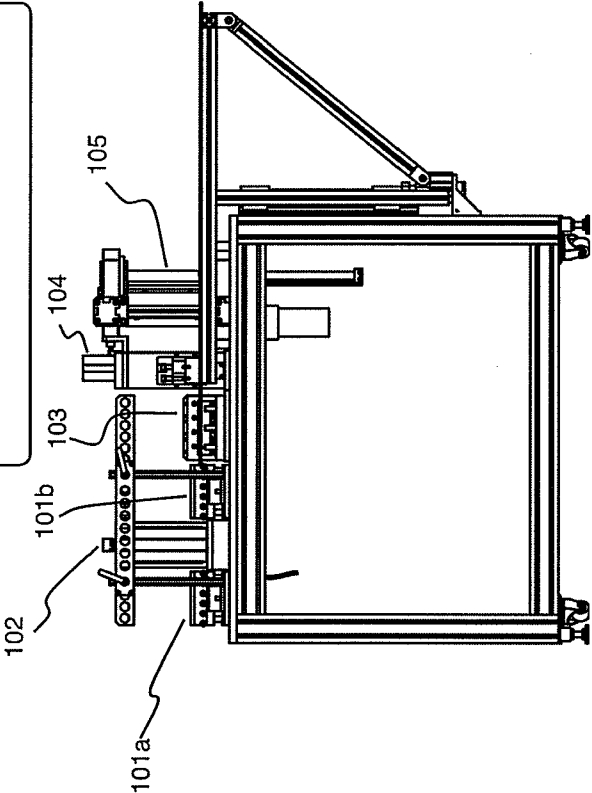
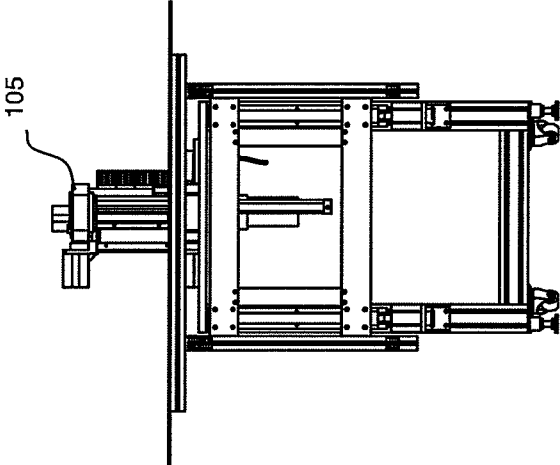

FIGURE 1C



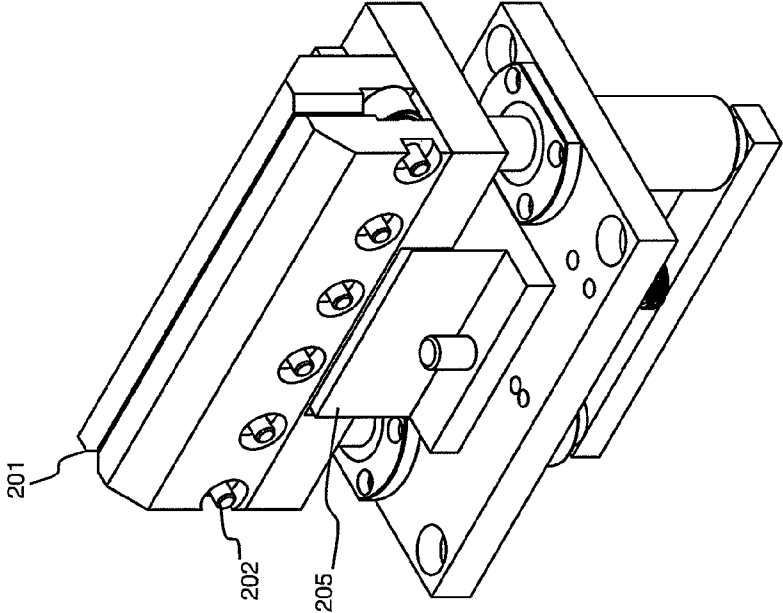

FIGURE 2C

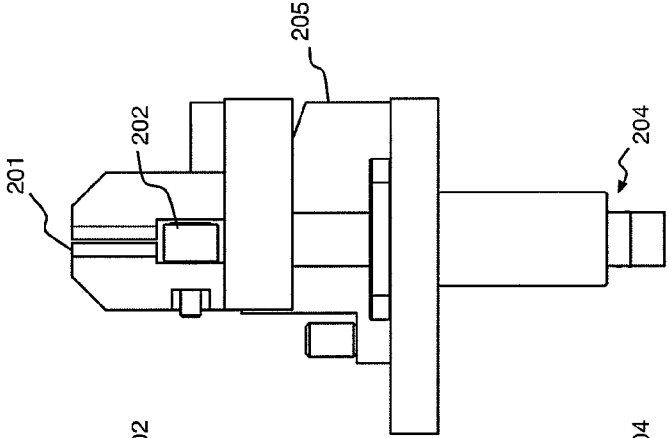

FIGURE 2B

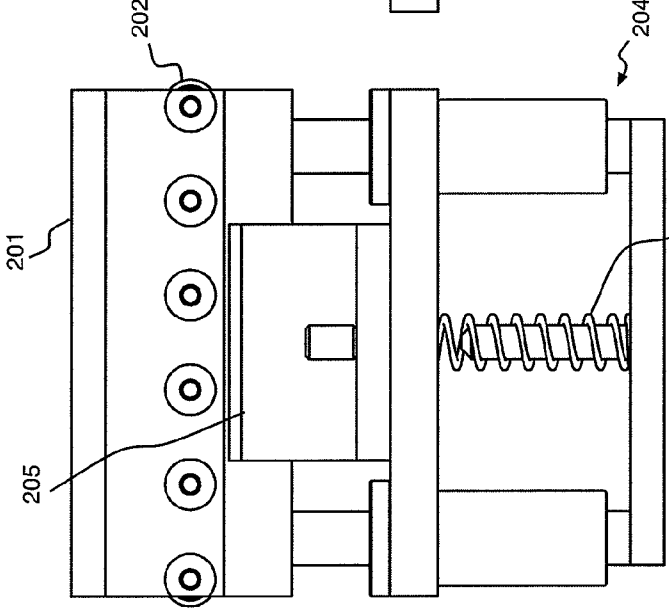

FIGURE 2A

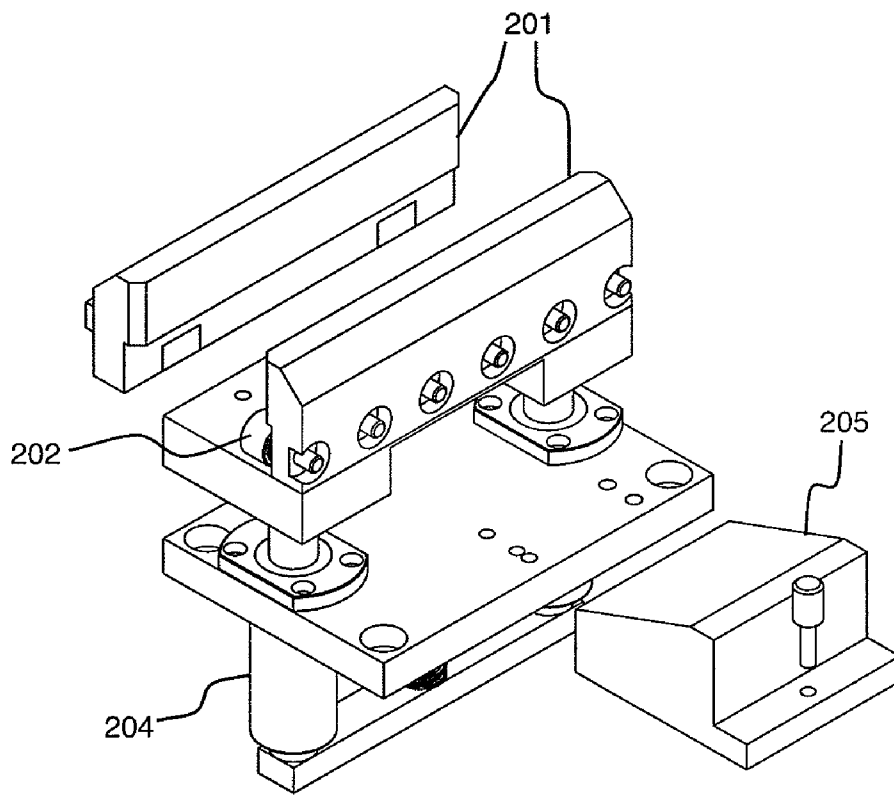

FIGURE 2D

FIGURE 3B

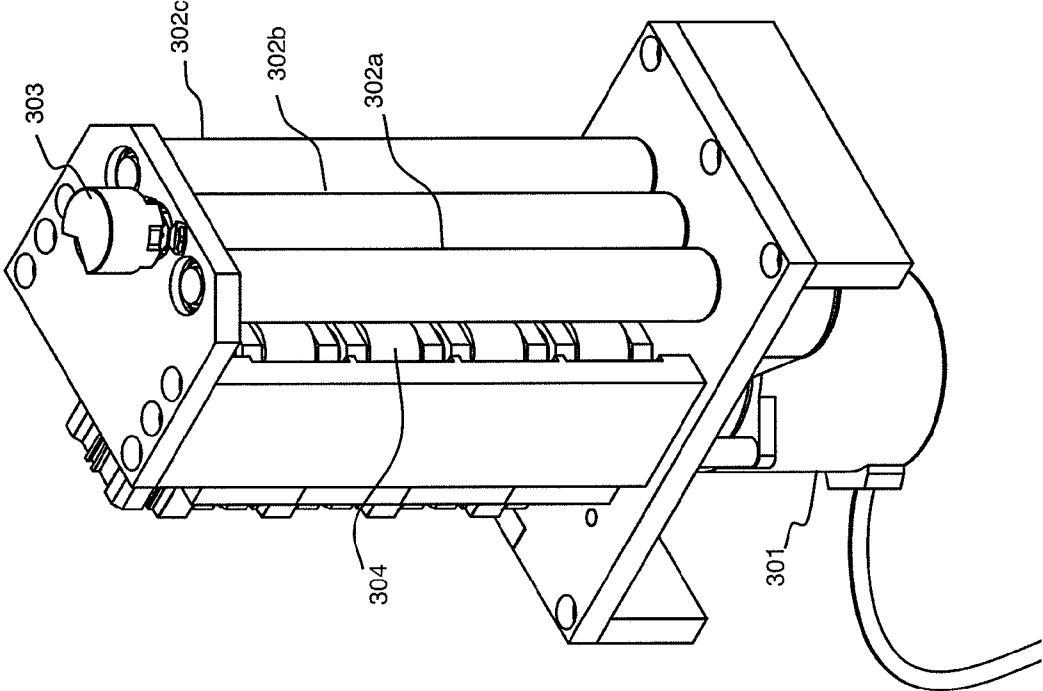
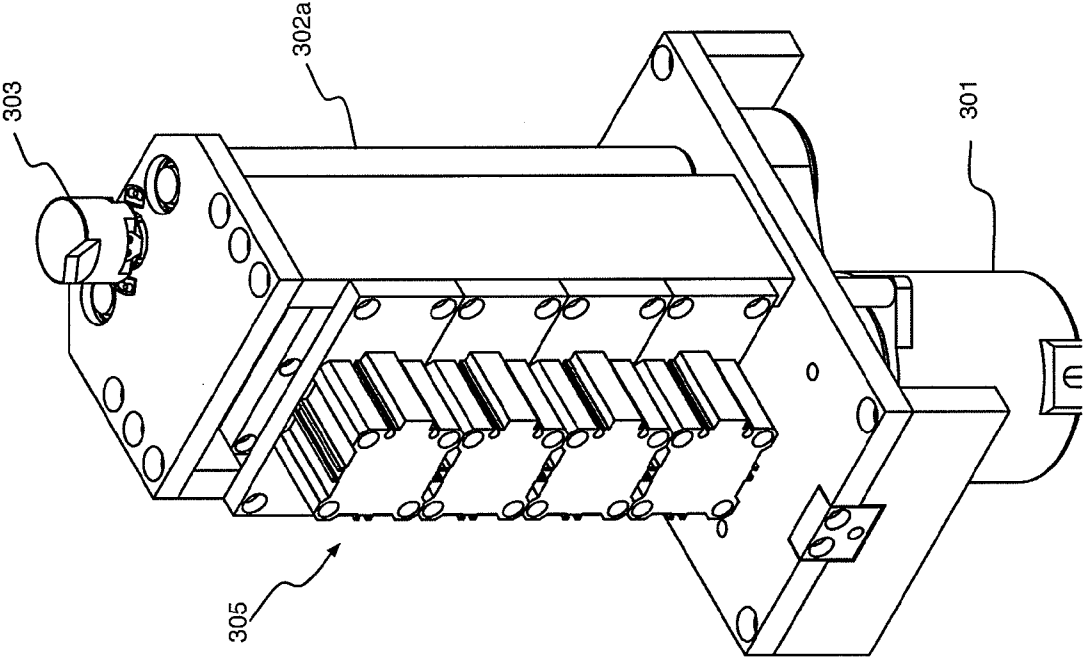

FIGURE 3A



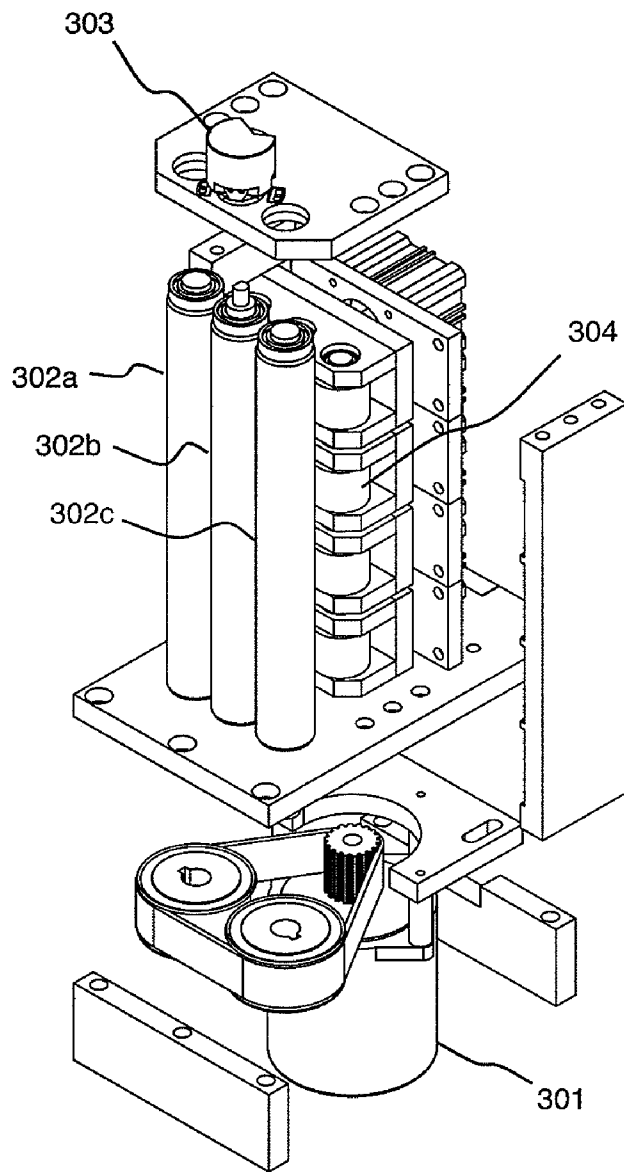

FIGURE 3C

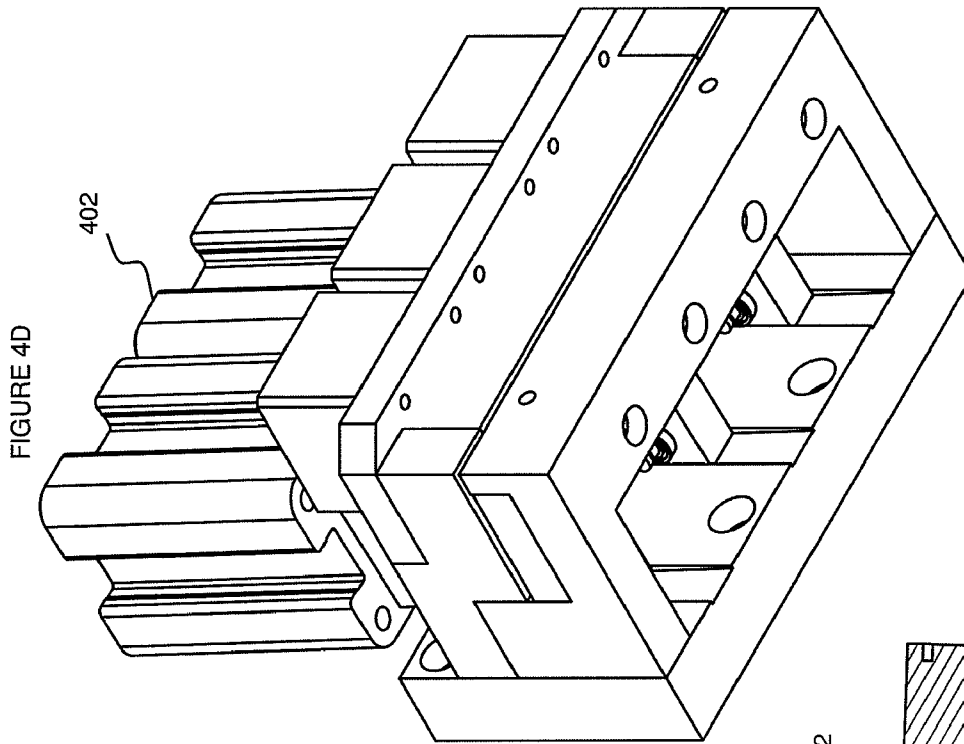

FIGURE 4D

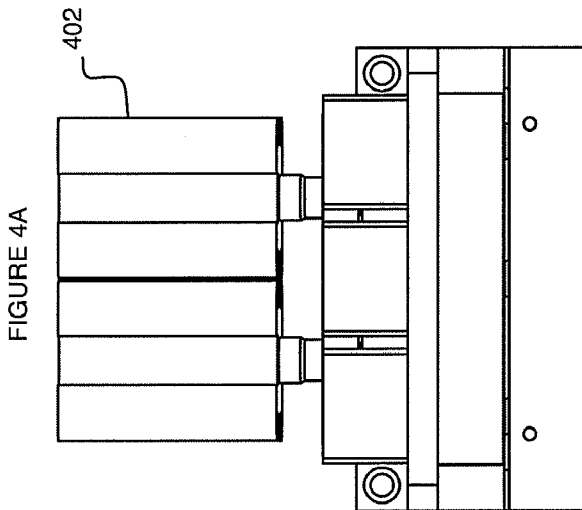
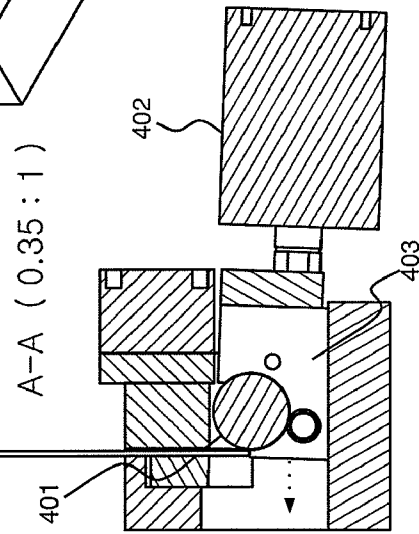

FIGURE 4A



A-A (0.35 : 1)

FIGURE 4C

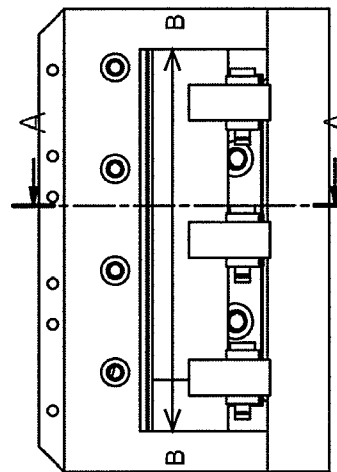

FIGURE 4B

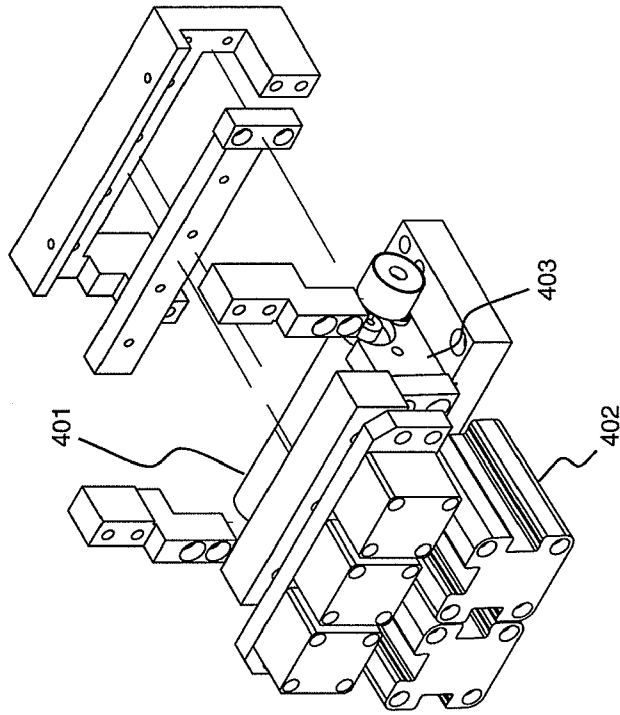

FIGURE 4F

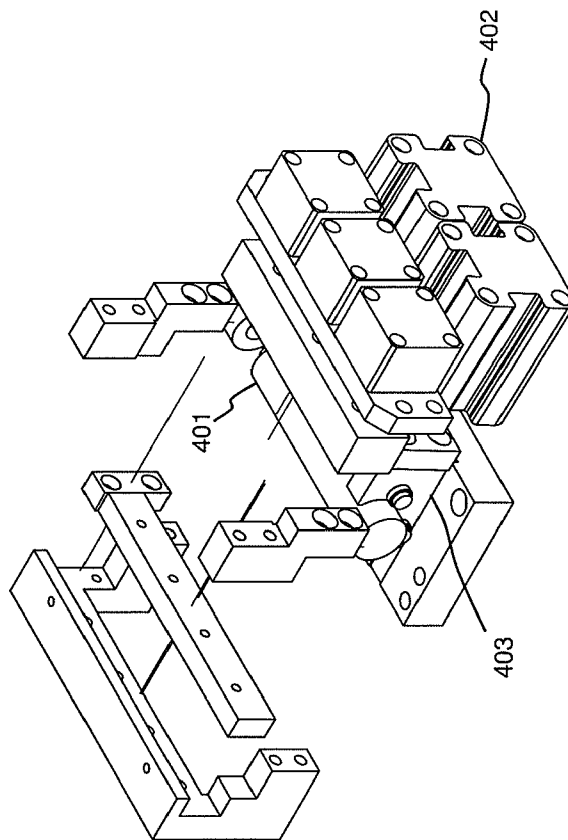

FIGURE 4E

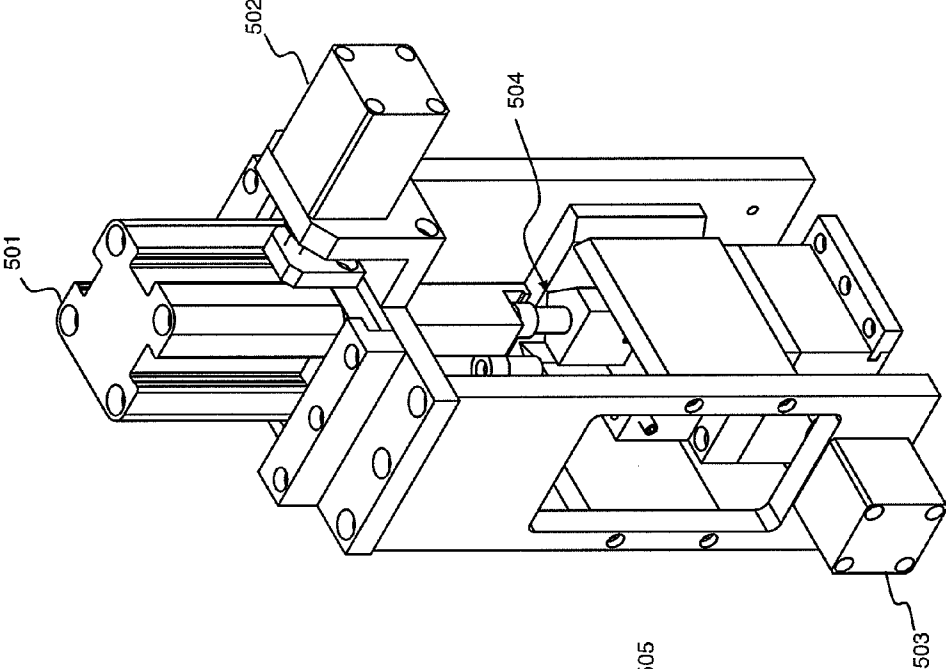

FIGURE 5D

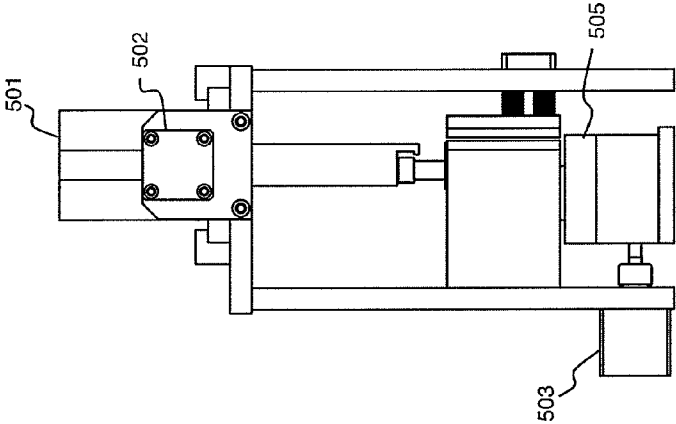

FIGURE 5C

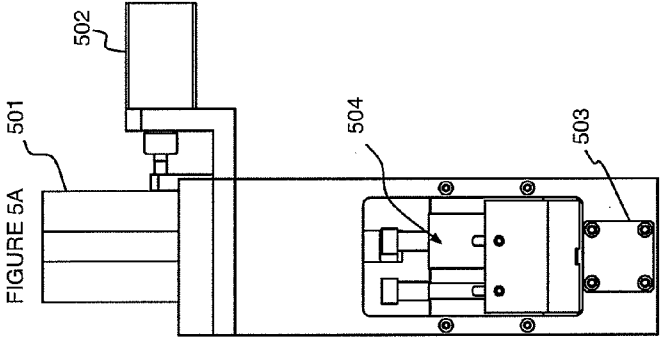

FIGURE 5A

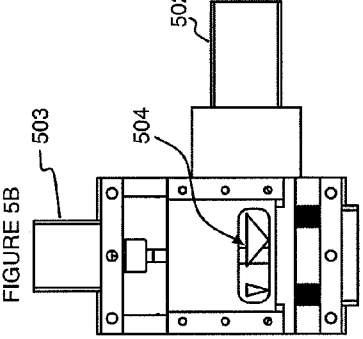

FIGURE 5B

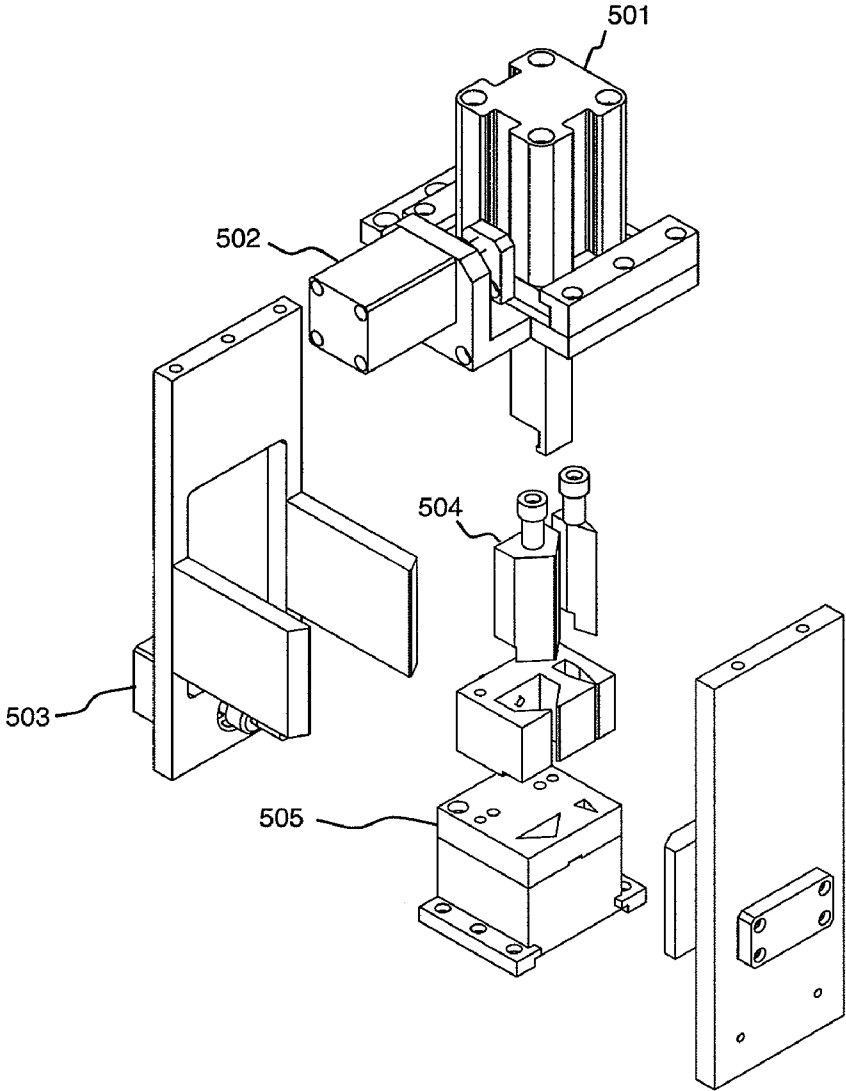

FIGURE 5E

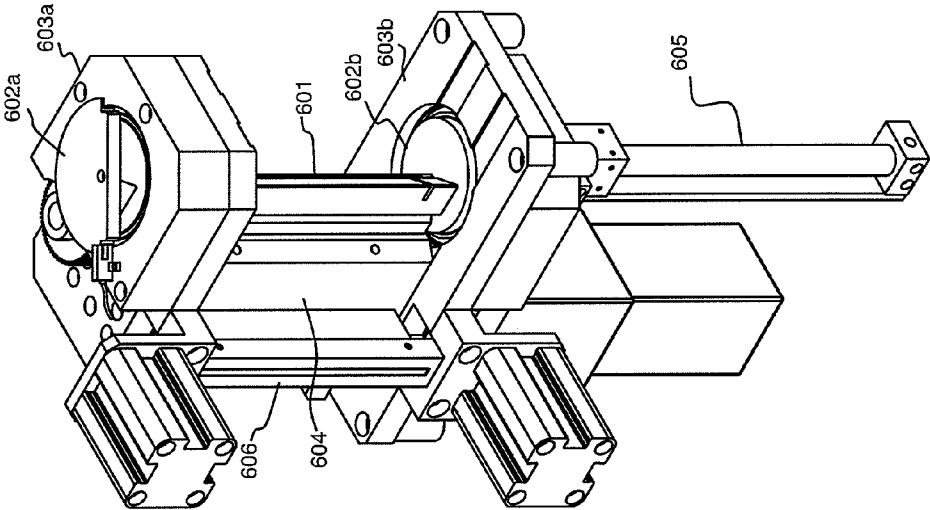

FIGURE 6C

FIGURE 6B

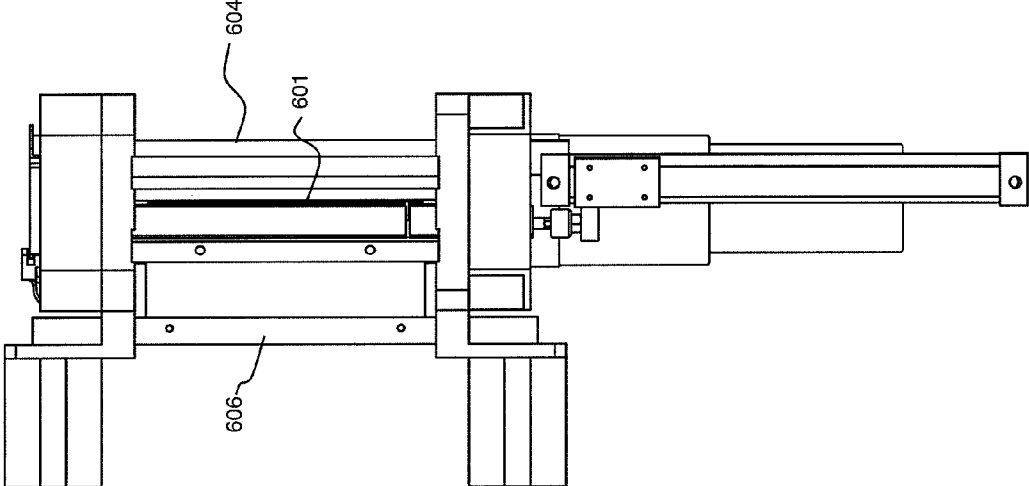
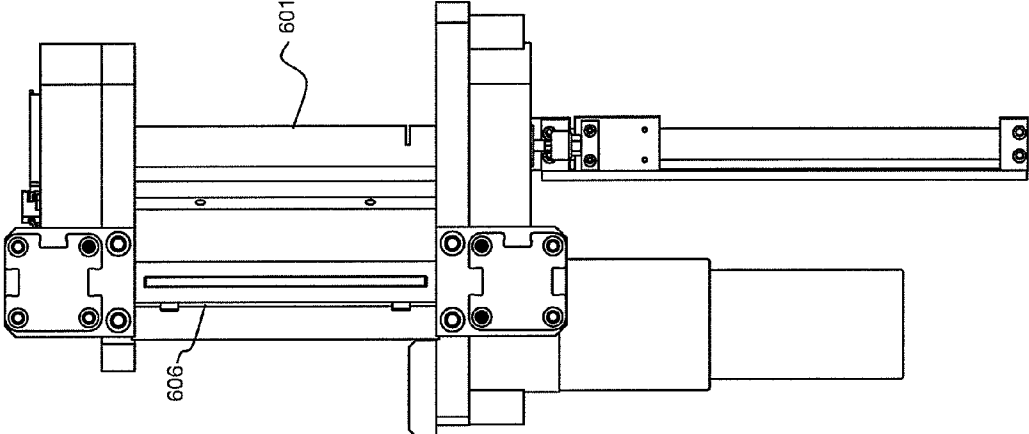

FIGURE 6A



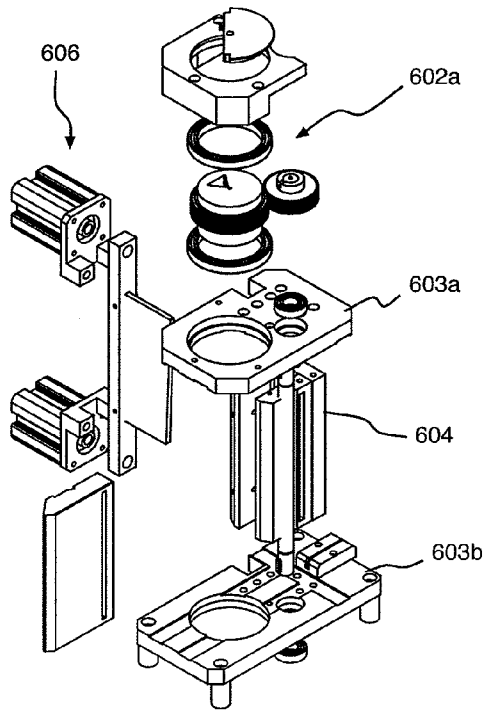

FIGURE 6D

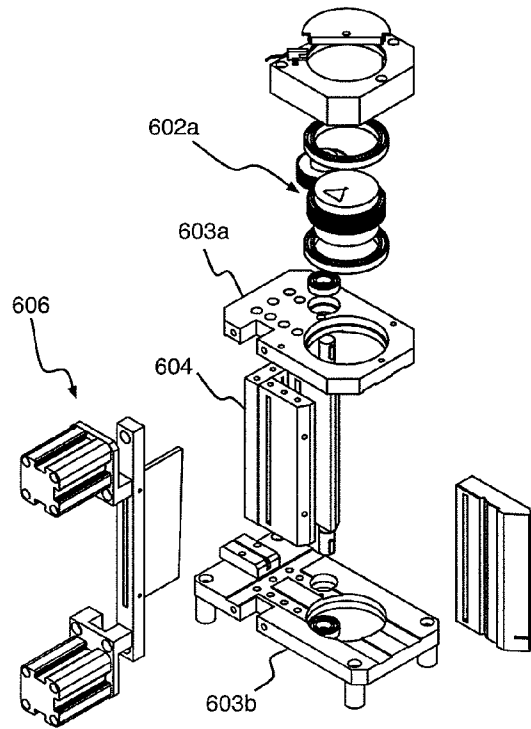
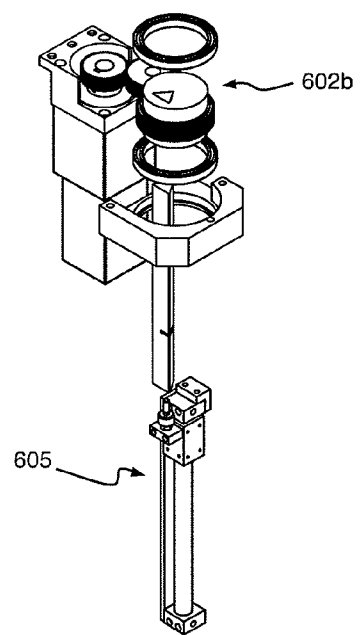
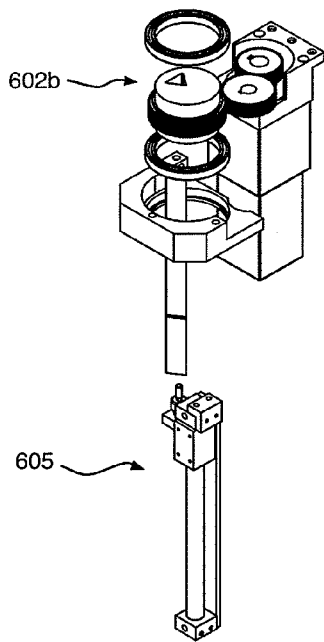

FIGURE 6E



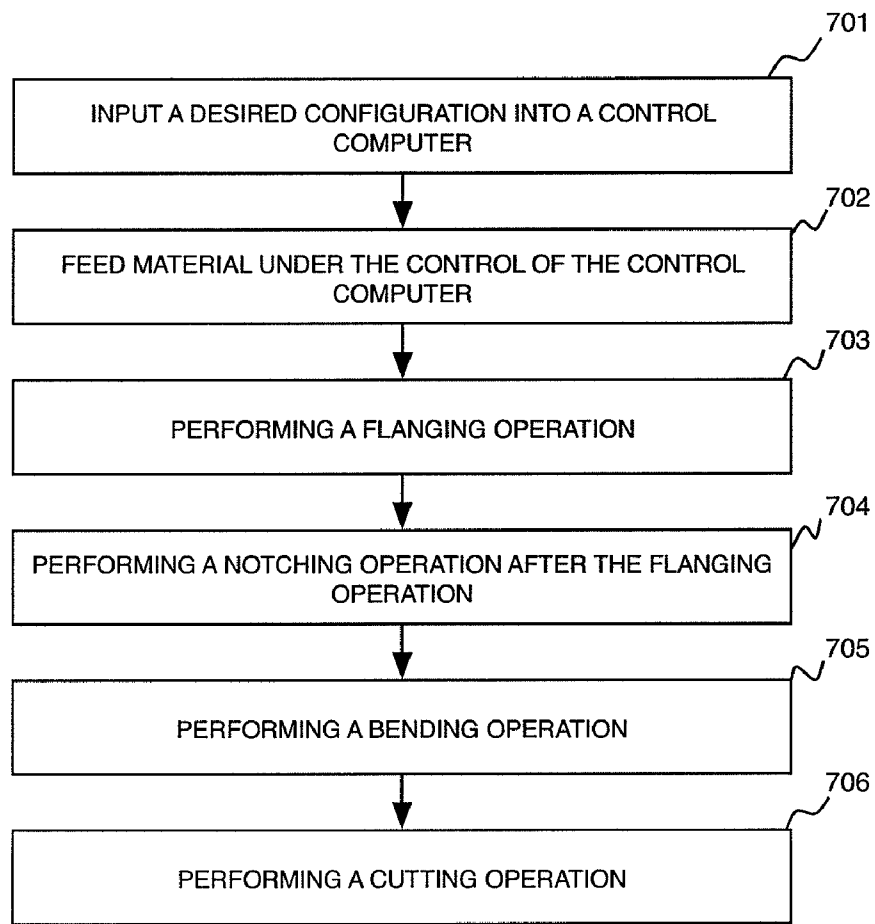

FIGURE 7

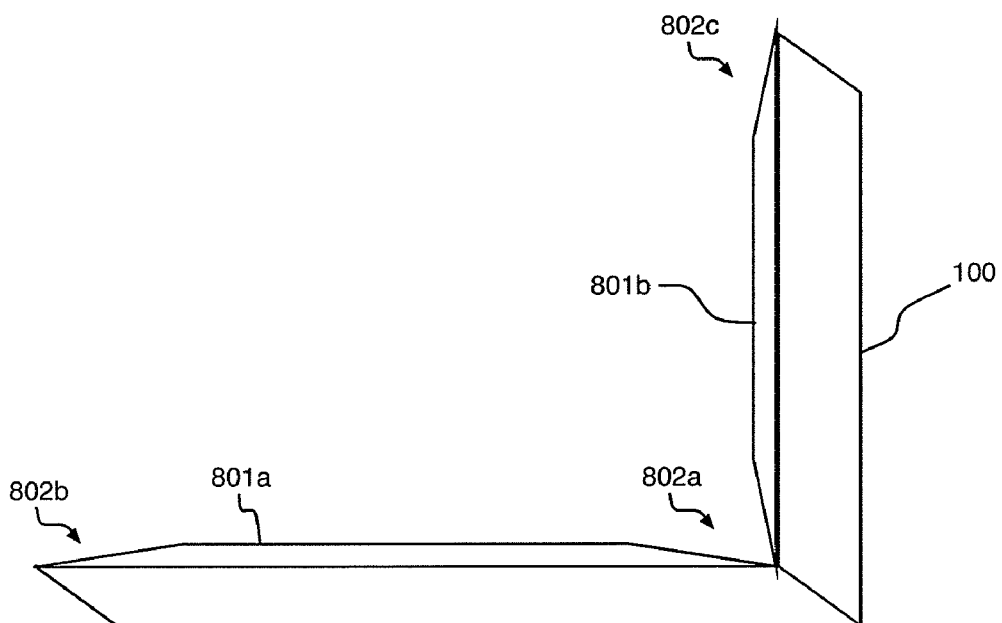

FIGURE 8

1

CHANNEL LETTER MACHINE AND METHOD THEREOF

BACKGROUND OF THE INVENTION

1. Field of the Invention

The present disclosure relates to a folding and cutting system and method, and more particularly to a channel letter machine used for manufacturing a predetermined design from sheet material.

2. Description of Related Art

A channel letter includes a face, for example, made from a transparent material such as plastic or metal, and a back, for example, made of metal or plastic. The front face and back can be cut manually or cut using computer controlled routers. The channel letter further includes a return or side of the channel letter disposed to connect the front face and the back.

The return may be made of metal. The return is formed into the shape of the front face and back.

Therefore, a need exists for a channel letter machine for manufacturing the return of a channel letter.

SUMMARY OF THE INVENTION

According to an embodiment of the present disclosure, a computer-implemented method of automatically bending a return of a channel letter comprises inputting a desired configuration for the return to a control computer and feeding a stock under the control of the control computer along a feed path including a flanging unit, a notching unit, and a bending unit that are arranged along the feed path for the stock, with the flanging unit being located upstream of the notching unit and the bending unit along the feed path. The method further comprises forming a flange on the bottom of the stock at desired flange positions on the stock at the flanging unit under the control of the control computer, notching the flange of the stock at locations corresponding to a position of bends at the notching unit under the control of the control computer, and bending the stock at the positions of the bends into the desired configuration for the return at the bending unit under the control of the control computer.

According to an embodiment of the present disclosure, a channel letter bending machine for automatically bending a return of a channel letter from a stock comprises a control computer for receiving a desired configuration for the return of the channel letter, and a feeding unit controlled by the control computer disposed along a path of travel of the stock to be bent for feeding the stock. The channel letter bending machine further comprises a flanging unit disposed along the path of travel for forming a flange along one edge of the stock, a notching unit disposed along the path of travel for notching the flange of the stock fed by the feeding mechanism along the path of travel, and a bending unit disposed along the path of travel for bending the stock under the control of the computer control system into the desired configuration for the channel letter shape, wherein the flanging unit is disposed upstream of the notching unit.

BRIEF DESCRIPTION OF THE DRAWINGS

Preferred embodiments of the present invention will be described below in more detail, with reference to the accompanying drawings:

FIGS. 1A-C are diagrams of a channel letter machine according to an embodiment of the present disclosure;

2

FIGS. 2A-D are diagrams of a guide of a channel letter machine according to an embodiment of the present disclosure;

FIGS. 3A-C are diagrams of a feeding unit of a channel letter machine according to an embodiment of the present disclosure;

FIGS. 4A-F are diagrams of a flanging unit of a channel letter machine according to an embodiment of the present disclosure;

FIGS. 5A-E are diagrams of a notching unit of a channel letter machine according to an embodiment of the present disclosure;

FIGS. 6A-E are diagrams of cutting tool and bending unit of a channel letter machine according to an embodiment of the present disclosure;

FIG. 7 is a flow chart of a method according to an embodiment of the present disclosure; and

FIG. 8 is an illustration of a portion of a return of a channel letter.

DETAILED DESCRIPTION OF PREFERRED EMBODIMENTS

According to an embodiment of the present disclosure, a channel letter machine for forming a return having a predetermined shape comprises a flanging assembly positioned upstream of a notching assembly and a bending assembly, facilitating efficient flanging of a stock by the flanging assembly without first notching the stock.

Referring to FIGS. 1A-C a channel letter machine comprises a guiding units **101a-101b**, a feeding unit **102**, a flanging unit **103** disposed upstream of a notching unit **104**, and a bending unit **105**. The channel letter machine further includes a control computer (not shown) for receiving commands for controlling the feeding unit **102**, the flanging unit **103**, the notching unit **104**, and the bending unit **105**.

The channel letter machine receives a stock material (hereinafter stock), e.g., a metal sheet material such as aluminum, and forms the return of a channel letter through flanging, notching, and bending operations.

Referring to FIGS. 2A-C, the guiding units **101a** and **101b** each include a guide **201**, guiding rollers **202**, a shock absorber **203**, and a height adjustment device **205**. The guide **201** holds the stock upright for being received by the feeding unit **102**, etc. The guide rollers **202** facilitate movement of the stock into the feeding unit **102** and the flanging unit **103**. The guide **201**, including the guiding rollers **202**, is supported by the height adjustment device **205**. The guiding unit **101** includes shafts **204** securing the guiding unit **101** in a horizontal position with respect to the channel letter machine. The guiding unit **101** may move in a vertical direction on the shafts **204**, supported by the shock absorber **203** and the height adjustment device **205** (the shock absorber **203** and the height adjustment device **205** operated independently). The height adjustment device **205** adjusts the height of the guide **201**, wherein a flanging depth or height can be adjusted.

Referring to FIGS. 3A and 3B, the feeding unit **102** includes a feed motor **301**, a feed rollers **302a** and **302c**, an encoder roller **302b**, an encoder **303**, and cylinder rollers **304**. The feed motor **301** drives the feed rollers **302a** and **302c** to pass the stock through the channel letter machine. The feeding unit **102** is height adjustable. The encoder **303** reads an actual advance of the stock according to a rotation of an encoder roller **302b**, which spins freely. As the stock is passed through the feeding unit **102**, the actual advance of the stock is determined. Should there be slippage of the stock against the feed rollers **302a** and **302c**, the control computer compen-

sates for the slippage, e.g., by performing flanging, notching, and bending according to the actual advance of the stock, such that flanges, notches and bends are formed at the appropriate positions. A plurality of counter rollers 304, e.g., four, may be engaged by corresponding cylinders 305 according to the height of the stock material. The computer determines and actuates the number of counter rollers 304 to engage according to the user's input of stock height. The counter rollers 304 are engaged by moving laterally, to press the stock against the feed rollers 302a-c. The counter rollers 304 apply substantially even pressure across the height of the stock and also the same to the top and bottom of feed unit. A number of counter rollers 304 may be controlled by each cylinder 305, for example, three cylinder rollers across, opposing the feeding rollers 302a and 302c, and the encoding roller 302b.

Referring to FIGS. 4A-4D, the flanging unit 103 includes a flanging roller 401 and a flanging actuator 402. The flanging actuator 402 is engaged to press the flanging roller 401 against the stock 100 to facilitate forming a flange. The flanging actuator pushes a carrier 403 laterally with respect to a surface of the stock 100 protruding into the flanging unit 103 (see FIG. 4C). The flanging roller 401 is disposed in the carrier 403 and is pressed against the stock 100 forming a flange. The flanging unit 103 cuts the stock 100 at the end positions of the flanges. The edge of the roller 401 works as a cutting tool to cut the flange, such that a flange may have one or more portions having a length equal to or less than a length of the flanging unit shown as B-B in FIG. 4B.

Referring to FIGS. 5A-D, a notching unit 104 includes a notch actuator 501, a notch selector 502, a stock engager 503 and at least one a notch cutter 504. As depicted in FIG. 5B, a bottom view of the notching unit 104, two different sized notch cutters may be implemented. The notch selector 502 selects a notch of a given size according to a desired configuration. The notch actuator 501 engages a selected cutter against a flange of the stock to cut a notch in the flange. The stock engager 503 includes a movable portion 505 that rises to push the stock against an opposite wall holding a flange of the stock firmly in place during the notching operation.

Referring to Figure FIGS. 6A-C, the bending unit 105 comprises a bending finger 601 and rotary bodies 602a and 602b for rotating the bending finger 601. The rotary bodies 602a and 602b are set in supporting frames 603a and 603b. The bending unit 105 includes a bending nozzle 604 of a size through which the stock, including the flanges, can be passed. The bending finger 601 is engaged by a bending finger actuator 605. The bending finger actuator 605 guides the bending finger 601 into place between the rotary bodies 602a and 602b. The bending finger 601, once disposed between the rotary bodies 602a and 602b may be rotated by the rotary bodies 602a and 602b to facilitate the bending function. The bending unit 105 further includes a cutting tool 606 for cutting the stock to a desired length. The cutting tool 606 moves in a direction substantially perpendicular to a plane of the stock, slicing the stock at end positions.

Referring to FIG. 7, a method of automatically bending a return of a channel letter includes inputting a desired configuration for the return to be formed into a control computer 701, and feeding a stock under the control of the control computer 702 along a feed path including a flanging unit, a notching unit, and a bending unit that are arranged along the feed path for the stock, with the flanging unit being located upstream of the notching unit and the bending unit along the feed path. The method further includes forming the flange on the bottom of the stock at desired flange positions on the stock at the flanging unit under the control of the control computer 703, notching a flange of the stock at locations corresponding to a

position of bends at the notching unit under the control of the control computer 704, and bending the stock at the positions of the bends into the desired configuration for the return at the bending unit under the control of the control computer 705. The stock may be cut at a cutting unit of the bending unit 706.

Each of a feeding operation, a flanging operation, a notching operation, and a bending operation are performed according to an input, e.g., inputs from a computer or user commands. According to the input a return may be formed without a flange, without a notch, and/or without a bend.

FIG. 8 depicts an exemplary stock 100, having flanges 801a-b, and notches 802a-c.

The control computer of the may be implemented in various forms of hardware, software, firmware, special purpose processors, or a combination thereof. In one embodiment, user commands may be implemented by software such as an application program tangibly embodied on a program storage device. The application program may be uploaded to, and executed by, a machine comprising any suitable architecture.

The control computer can comprise, inter alia, a central processing unit (CPU), a memory and an input/output (I/O) interface. The computer system is coupled through the I/O interface to the feeding unit 102, the flanging unit 103, the notching unit 104 and the bending unit 105. The computer system may include various input devices such as a mouse and keyboard. User commands may be processed by a routine that is stored in memory and executed by the CPU. As such, the computer system is a general purpose computer system that becomes a specific purpose computer system when executing the routine.

It is to be further understood that, because some of the constituent system components and method steps depicted in the accompanying figures may be implemented in software, the actual connections between the system components (or the process steps) may differ depending upon the manner in which the present invention is programmed. Given the teachings of the present invention provided herein, one of ordinary skill in the related art will be able to contemplate these and similar implementations or configurations of the present invention.

Having described embodiments for a system and method for a channel letter machine used for manufacturing a predetermined design from sheet material, it is noted that modifications and variations can be made by persons skilled in the art in light of the above teachings. It is therefore to be understood that changes may be made in embodiments of the present disclosure that are within the scope and spirit thereof.

What is claimed is:

1. A computer-implemented method of automatically bending a return of a channel letter comprises:
 - inputting a desired configuration for the return to be formed into a control computer;
 - feeding a stock under the control of the control computer along a feed path including an encoder, a flanging unit, a notching unit, and a bending unit that are arranged along the feed path for the stock, with the flanging unit being located downstream of the encoder and upstream of the notching unit and the bending unit along the feed path; selectively forming a flange on the bottom of the stock at desired flange positions on the stock at the flanging unit under the control of the control computer;
 - notching the flange of the stock at locations corresponding to a position of bends at the notching unit under the control of the control computer; and
 - bending the stock at the positions of the bends into the desired configuration for the return at the bending unit under the control of the control computer.

5

2. The computer-implemented method of claim 1, further comprising cutting the stock at a cutting unit.

3. The computer-implemented method of claim 1, further comprising setting a height of at least one guide for controlling a depth of the flange, wherein the guide supports a bottom edge of the stock controlling a height of the stock relative to the flanging unit.

4. The computer-implemented method of claim 1, wherein feeding the stock under the control of the control computer further comprises:

determining an amount of stock passing an encoder; and performing at least one of the steps of forming the flange, notching the flange, and bending the stock according to the amount of stock passing the encoder.

5. The computer-implemented method of claim 1, wherein forming the flange further comprises simultaneously cutting the flange.

6. A channel letter bending machine for automatically bending a return of a channel letter from a stock, comprising: a control computer for receiving a desired configuration for the return of the channel letter;

a feeding unit controlled by the control computer disposed along a path of travel of the stock to be bent for feeding the stock, wherein the feeding unit comprises an encoder for determining an amount of stock passing through the feeding unit;

a flanging unit disposed along the path of travel for selectively forming a flange along one edge of the stock;

a notching unit disposed along the path of travel for notching the flange of the stock fed by the feeding mechanism along the path of travel; and

a bending unit disposed along the path of travel for bending the stock under the control of the computer control system into the desired configuration for the channel letter shape, wherein the flanging unit is disposed upstream of the notching unit.

7. The channel letter bending machine of claim 6, wherein the bending unit further comprises a cutting unit for cutting the stock.

8. The channel letter bending machine of claim 6, further comprising at least one guide for setting a depth of the flange, wherein the guide supports a bottom edge of the stock controlling a height of the stock relative to the flanging unit.

9. The channel letter bending machine of claim 8, wherein a first guide is disposed upstream of the feeding unit.

10. The channel letter bending machine of claim 8, wherein a first guide is disposed downstream of the feeding unit.

11. The channel letter bending machine of claim 8, wherein the at least one guide is height adjustable for setting a depth of the flange.

6

12. The channel letter bending machine of claim 6, wherein the control computer transmits commands to at least one of the feeding unit, the flanging unit, the notching unit, and the bending unit according to the amount of stock passing through the feeding unit.

13. The channel letter bending machine of claim 6, wherein the notching unit and the flanging unit are disposed upstream of the bending unit.

14. The channel letter bending machine of claim 6, wherein the flanging unit comprises a cutting tool for cutting the flange.

15. A channel letter bending machine for automatically bending a return of a channel letter from a stock, comprising: a control computer for receiving a desired configuration for the return of the channel letter;

a feeding unit controlled by the control computer disposed along a path of travel of the stock to be bent for feeding the stock;

a flanging unit disposed along the path of travel for selectively forming a flange along an edge of the stock;

a notching unit disposed along the path of travel for notching the flange of the stock fed by the feeding mechanism along the path of travel; and

a bending unit disposed along the path of travel for bending the stock under the control of the computer control system into the desired configuration for the channel letter shape, wherein the flanging unit is disposed upstream of the notching unit.

16. The channel letter bending machine of claim 15, wherein the flanging unit comprises a cutting tool for cutting the flange.

17. The channel letter bending machine of claim 15, further comprising at least one guide for setting a depth of the flange, wherein the guide supports a bottom edge of the stock controlling a height of the stock relative to the flanging unit.

18. The channel letter bending machine of claim 15, wherein a first guide is disposed upstream of the feeding unit.

19. The channel letter bending machine of claim 15, wherein a first guide is disposed downstream of the feeding unit.

20. The channel letter bending machine of claim 15, wherein the feeding unit comprises an encoder for determining an amount of stock passing through the feeding unit, wherein the control computer transmits commands to at least one of the feeding unit, the flanging unit, the notching unit, and the bending unit according to the amount of stock passing through the feeding unit.

* * * * *